



Techni
ENGINEERING SOLUTIONS

FORD ALL-NEW TRANSIT RWD STAGE 5/6

350, 430, 470.

EURO 5/6 - 100, 125, 155 PS

CODE / CODICE: 0500.7412

**COMPRESSOR / COMPRESSEUR / KOMPRES-
SOR / COMPRESSORE / COMPRESOR :
DELPHI SP15**

**FITTING INSTRUCTIONS
EINBAUANLEITUNGEN
INSTRUCTIONS POUR LE MONTAGE
ISTRUZIONI DI MONTAGGIO
INSTRUCCIONES DE MONTAJE**

Contents

ENGLISH	4
Parts View.....	4
Parts List	5
Compressor Configurations	6
Standard Fastener Torque Values	6
Kit Details	7
Vehicle Details	7
Forward	7
Pre Installation.....	8
Drive Pulley Installation	9
Idle Pulley Installation	10
Tensioner Installation	10
Compressor installation.....	11
Drive belts.....	11
Post Installation	12
Compressor Installation.....	14
Post Installation.....	15
Fan Hub Spacer Installation	15

PARTS VIEW / VUE ÉCLATÉE / TEILEANSICHT / VISTA PARTA / IMÁGENES DE LAS PIEZAS

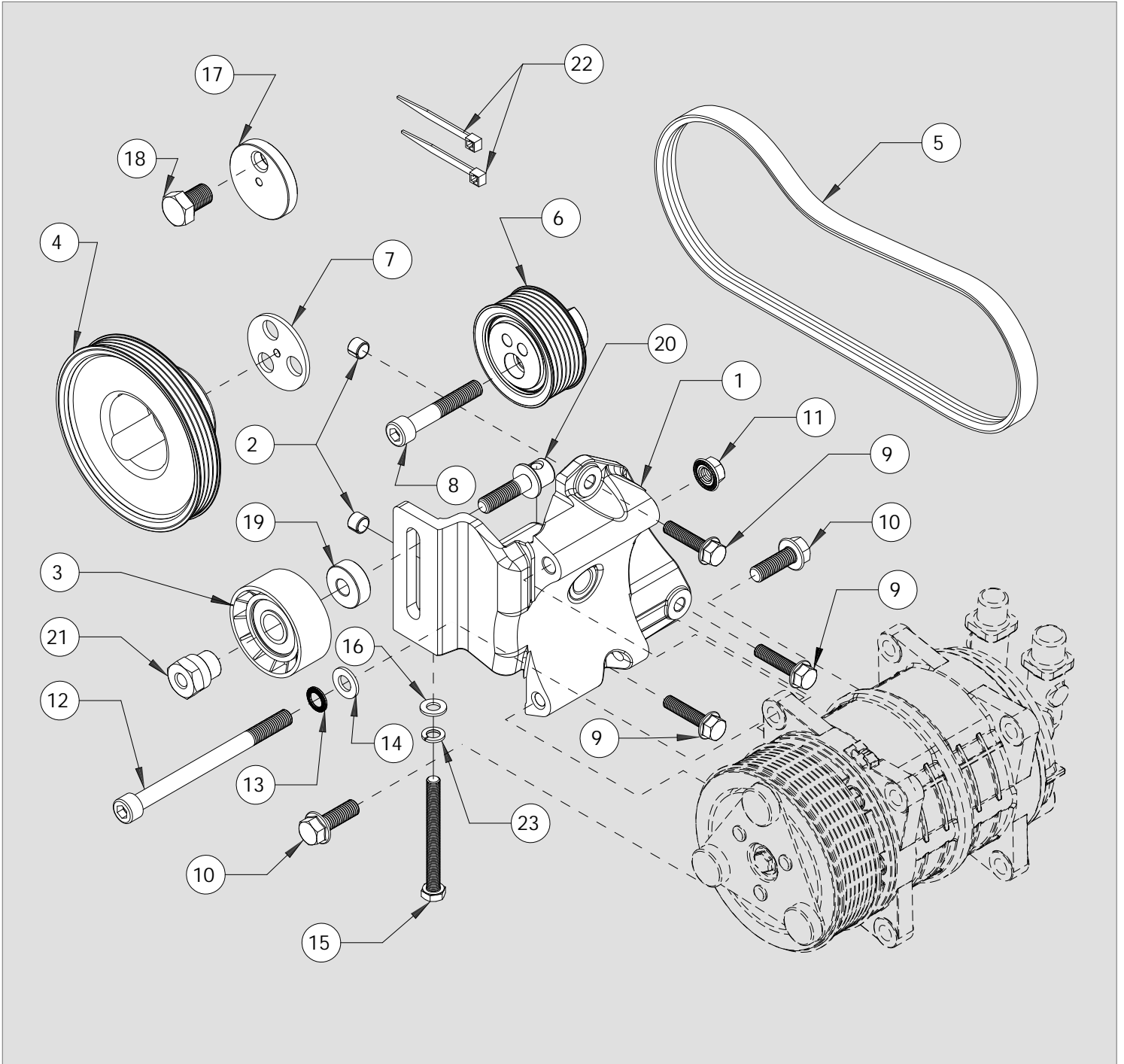

PARTS LIST / NOMENCLATURE / TEILELISTE / ELENCO DELLE PARTI / LISTA DE PIEZAS

ITEM	CODE / CODICE / KODE / CODIGO	DESCRIPTION / DESCRIZIONE / BESCHREIBUNG / DESCRIPCION	QTY.	COMMENTS
1	0440.2244	Compressor Mount Bracket Assembly	1	-
2	2800.5533	Split Dowel Bush	2	-
3	1700.5212	Idle Pulley 70 X 22	1	-
4	1701.5043	Crankshaft Drive Pulley	1	-
5	0820.5171	Belt - Poly Groove 4PK 0975	1	-
6	1700.5153	Idle Pulley - Ford Transit RWD 2.2 E5 7 PK	1	-
7	2803.5263	Spacer - Transit Crankshaft SMF	1	-
8	2705.5051	Hex socket head cap screw M10 x 60 : 1.50 - 12.9	1	-
9	2704.0481	Hex flange bolt Durlok - M8 x 35 : 1.25 - 12.9	3	-
10	2705.0491	Hex flange bolt Durlok - M10 x 30 : 1.50 - 12.9	2	-
11	2735.0071	Durlok Hexagon Flange Nut - M10 : 1.50	1	-
12	2705.0301	Hex socket head cap screw M10 x 130 : 1.50 - 12.9	1	-
13	2809.0101	M10 Schnorr safety washer type 'S'	1	-
14	2809.0011	Washer M10 Flat DIN 125 - A 10.5	1	-
15	2719.0081	Hex Set screw - M8 X 80 : 1.25 - 8.8	1	-
16	2808.0011	Washer M8 Flat DIN 125 - A 8.4	1	-
17	2803.3773	Crankshaft Pulley Drilling Jig	1	-
18	2723.0041	Bolt 1/2 x 0.75 - 20 UNF	1	-
19	2803.5951	Idle Pulley Spacer - 24OD x 10.5ID x 12.5	1	-
20	1703.0153	Idle Pulley Eye Bolt	1	-
21	1710.0073	Idle Pulley Nut	1	-
22	2763.0051	Cable Tie 5 x 370 - Black	2	-
23	2808.0031	Spring washer M8 x 1.6 - ID 8.3 OD 14.0	1	-

**COMPATIBLE COMPRESSORS / COMPRESSEURS RECOMMANDÉS / EMPFOHLENE KOMPRESSOREN
RACCOMANDATO COMPRESSORI / RECOMENDADAS COMPRESORES**

SELTEC	TM-13 HS	TM15-HS	TM16-HS
Comp No	0381.0202	0381.0002	0381.0312
Valeo No.	488-45120	488-55120	488-46134
Mounting	Ear	Ear	Ear
Rotor	8PV	8PV	8PV
GL	-	-	-
Armature	3E	3E	3E
Diameter	123	123	123
Voltage	12	12	12
Orientation	V	V	V
Fitting	3/4 x 7/8	3/4 x 7/8	3/4 x 7/8
Manifold	Bolt	Bolt	Bolt

QUE	QP13-HD	QP15-HD	QP16-HD
Comp No	0391.0202	0391.0002	0391.0312
Que No.	QP13-1302	QP15-1171	QP16-1581
Mounting	Ear	Ear	Ear
Rotor	8PV	8PV	8PV
GL	-	-	-
Armature	3E	3E	3E
Diameter	123	123	123
Voltage	12	12	12
Orientation	V	V	V
Fitting	3/4 x 7/8	3/4 x 7/8	3/4 x 7/8
Manifold	Bolt	Bolt	Bolt

SANDEN	-	SD5H14	SD7H15
Comp No	-	0300.0461	0300.2001
Sanden No.	-	6629	8026
Mounting	-	Ear	Ear
Rotor	-	7PV	6PV
GL	-	-	-
Armature	-	SL	SL
Diameter	-	124	125
Voltage	-	12	12
Orientation	-	V	V
Fitting	-	3/4 x 7/8	3/4 x 7/8

NOTES

STANDARD FASTENER TORQUE VALUES

In the absence of specific torque values detailed in this fitting instruction manual, the following chart can be used as a guide to the maximum safe torque for specific size and grade of fastener.

COUPLES DE SERRAGE DES FIXATIONS STANDARDS

Si des chiffres de serrage au couple particuliers ne sont pas indiqués dans cette notice de montage, se référer au tableau suivant qui servira de guide pour le couple de sécurité maximum correspondant à une taille et un grade spécifiques de fixation.

ANZIEHMOMENTE FÜR STANDARDBEFESTIGUNGSMITTEL





Falls in dieser Einbauanleitung keine speziellen Anziehmomente angegeben sind, kann die folgende Tabelle als Richtlinie für das maximale sichere Anziehmoment für eine spezifische Größe oder Qualität von Befestigungsmitteln dienen.

VALORI STANDARD DI SERRAGGIO PER DISPOSITIVI DI FISSAGGIO

In assenza di valori specifici di coppia nel presente manuale di istruzioni, si può utilizzare la seguente tabella come guida per conoscere la coppia massima sicura in base a dimensioni e grado del dispositivo di fissaggio.

VALORES ESTÁNDAR DE LOS PARES DE APRIETE Y FIJACIÓN

En ausencia de valores para los pares de apriete específicos detallados en este manual de instrucciones de montaje, se puede utilizar la siguiente tabla como guía para consultar el máximo par de torsión seguro para un tamaño concreto y su grado de fijación.

STRENGTH								
	Max Torque		Max Torque		Max Torque		Max Torque	
Dia / Pitch	lb.ft	Nm	lb.ft	Nm	lb.ft	Nm	lb.ft	Nm
M5 x 0.80	2	3	4.5	6	6.5	9	7.5	10
M6 x 1.00	4	5.5	7.5	10	11	15	13	18
M8 x 1.25	10	13	18	25	26	35	33	45
M10 x 1.25	20	27	39	53	57	78	66	90
M10 x 1.50	18	25	37	50	55	73	63	86
M12 x 1.75	33	45	63	85	97	130	111	150
M14 x 2.00	55	75	103	140	151	205	177	240
M16 x 2.00	85	115	159	215	232	315	273	370

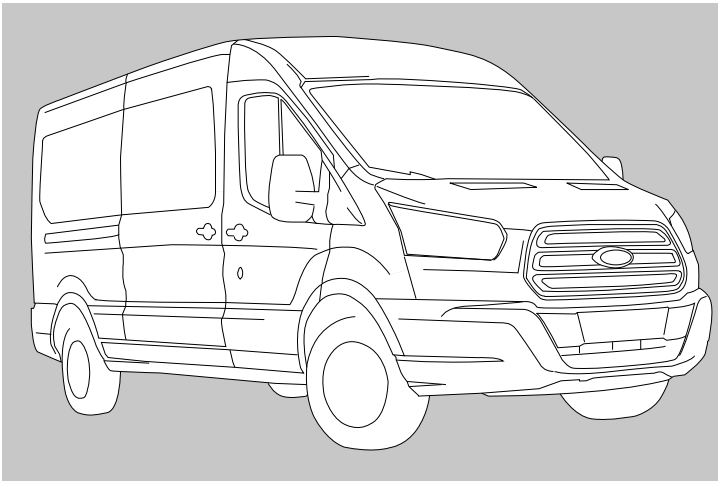

VEHICLE DETAILS

Manufacturer	Ford
Make	All-New Transit RWD Stage 5/6
Model	350, 430, 470
Engine CC	2198cc
Engine Details	Euro 5/6 - 100, 125, 155 PS
Year	01.2014 >
Type	V363
LHD	YES
RHD	YES
PAS	YES
A/C	NO
Voltage	12v

KIT DETAILS

Kit Part No.	0500.7412
Description	Standard Kit
Compressor RPM	3500
Fitting Time	60 Minutes
Suction Fitting	90°
Discharge Fitting	90°
Belt Type	4PK 0975
Belt Part No.	0820.5171

Note: Check original crankshaft damper before commencing installation, see Fig 5.

FOREWORD

The purpose of this manual is to facilitate the installation of a direct drive compressor. The information given is merely instructive, should any complications arise contact the Technical department. The manufacturer's warranty does not cover any problems caused by defective installation or alterations made unless authorised. The manufacturer shall not be responsible for any injury, damage or loss caused directly or indirectly as a result of using this manual or the information contained within it.

1 SAFETY MEASURES:

Before fitting the Compressor adapter drive kit, ensure the following for damage:

- a Inner and outer trim and body work
- b Engine idle pace
- c Check all the vehicle functions

Check list:

- a Ensure that the right kit has been selected
- b Before installing, check that all the correct pieces are present; also ensure that there are no missing or broken pieces
- c When fitting, make sure the vehicle is properly protected against damage.

Installation apparatus

- a Calibrated torque wrench
- b Hand service tools
- c Protective covers and shields

2 PRECAUTIONS

- a Detach the battery negative lead.
- b Torque all bolts where stated using a calibrated torque wrench.
- c Take extreme care with moving parts.
- d Remove the vehicle's ignition key and keep it with you.
- e Wear safeguards and make sure that liquid refrigerant never touches your skin

Caution: Measures must be followed accurately to steer clear of the possibility of damage to individuals

Warning: This calls awareness to actions which must be pursued to avoid damage to the components.

NB: This calls awareness to make the job easier or gives useful information.

N.B Prior to commencing work, please examine the instructions with care. The alphabetical symbols on the diagram relate to written instructions, numerical symbols relate to the parts listing.

PRE-INSTALLATION

1. Disconnect the battery and remove the ignition key from the vehicle. Using a Viscous fan removal tool (not supplied) remove the viscous fan assembly from the engine.
2. Using a suitable tool rotate the automatic belt tensioner (A) to release the tension and lock with a pin at point (B) remove the original manufacturer's drive belt (C) taking care to check the direction of rotation and noting the original routing, if different from the diagram shown in Fig.14 report your findings to your Kit/System supplier before proceeding - Fig 1

Warning: To avoid damage to the engine dual mass flywheel the subsequent method must be performed correctly. DO NOT LOCK THE ENGINE BY REMOVING THE CRANKSHAFT SENSOR

3. Temporarily move the cable (D) to gain access to the starter motor bolt (E) - Fig 2
4. Temporarily remove the two bolts (E) that fasten the starter motor (F) to the engine - Fig 2
5. Move the starter motor (F) to gain access to the flywheel ring gear. Using a suitable tool lock the engine ring gear at point (G) - Fig 3

6. Remove the three bolts (H) retaining the engine crankshaft damper and carefully remove the damper - Fig 1
7. Remove the original manufacturers loom (I) from the two mounting holes (J) located on the near side of the engine block and tie back in a suitable location - Fig 4

Warning: Take care when removing the mounting clips securing the loom from the engine block to avoid damage to the threads - Fig 4

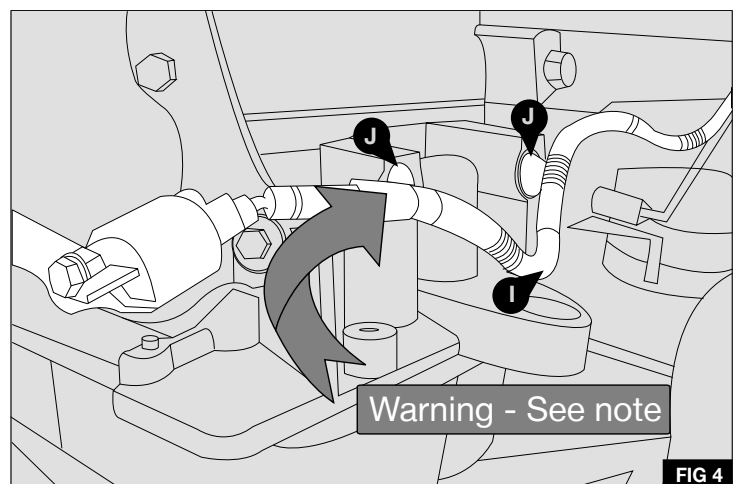
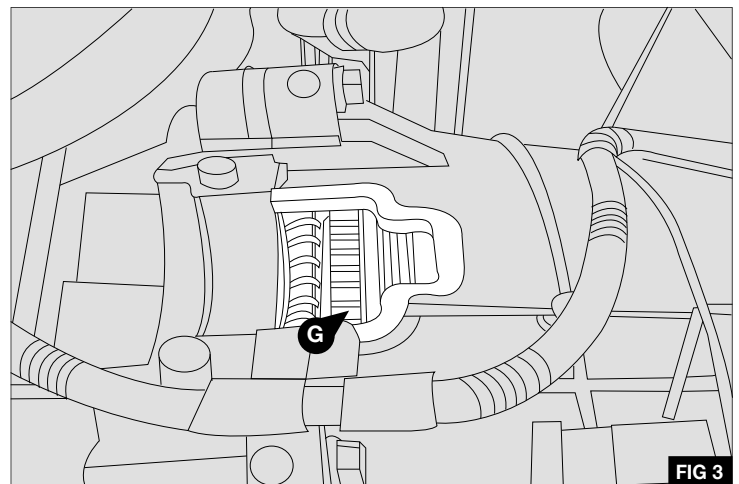
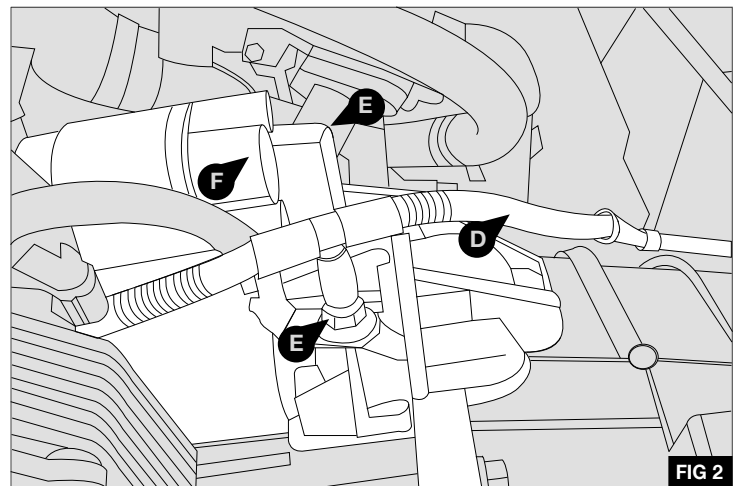
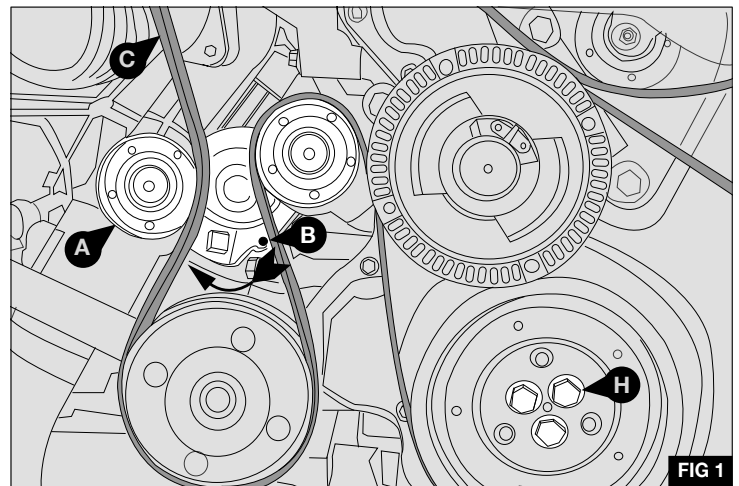

DRIVE PULLEY INSTALLATION

1. Check the type of engine crankshaft damper fitted to the vehicle, Single Mass Flywheel (SMF) or Dual Mass Flywheel (DMF) - Fig 5

Warning: Check engine crankshaft damper specification, part number is moulded onto the front of the damper.

2. Mount the drilling jig (17) to the rear of the previously removed engine damper fixing it with bolt (18) - Fig 6
3. Drill a 5mm hole through the drilling jig and crankshaft damper.

Warning: Centralise the drilling jig (17) between the locating lugs on the damper.

- Single Mass Flywheel (SMF) - Only**
4. Assemble the supplied crankshaft pulley (4) and spacer (7) to the original crankshaft damper type (K) and fix to the original position using the original bolts (H) - Fig 7

- Dual Mass Flywheel (DMF) - Only**
5. Assemble the supplied crankshaft pulley (4) and to the original crankshaft damper type (L) and fix to the original position using the original bolts (H) - Fig 8

Warning: Bolts are to be used 3 times only, each time they are removed they are to be centre punched to show they have been used.

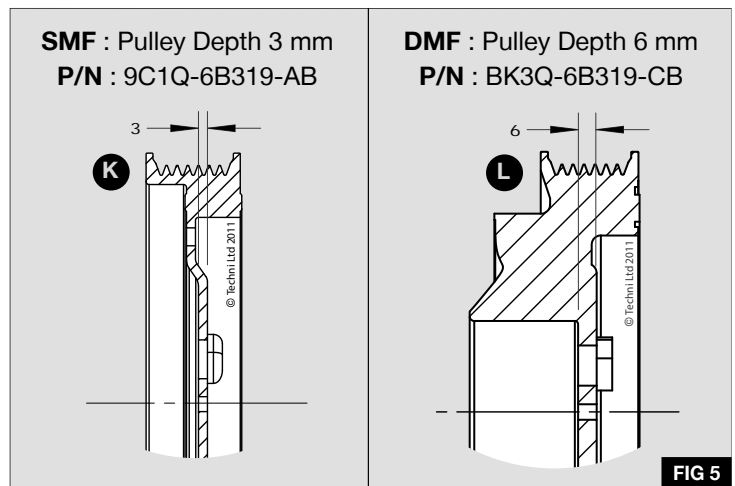

FIG 5

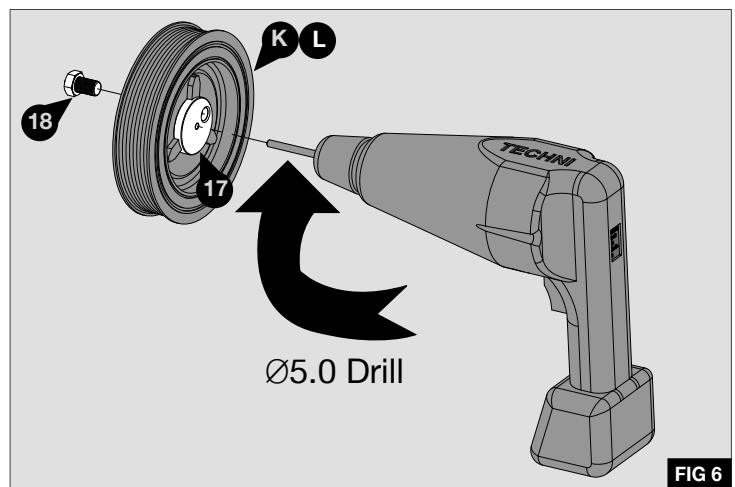

FIG 6

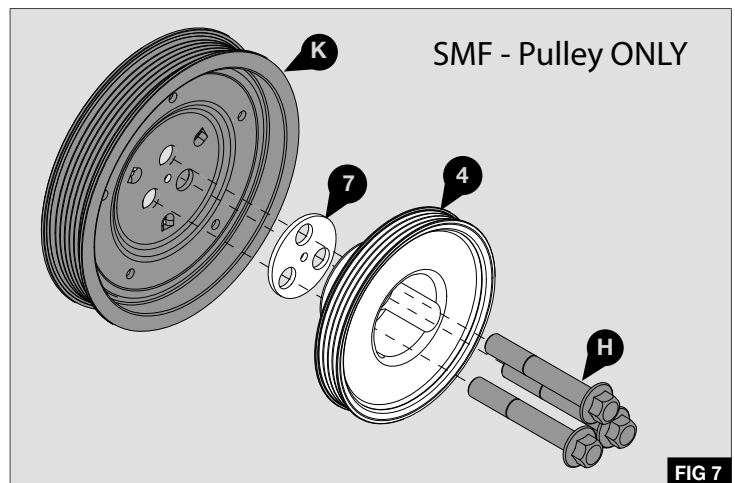

FIG 7

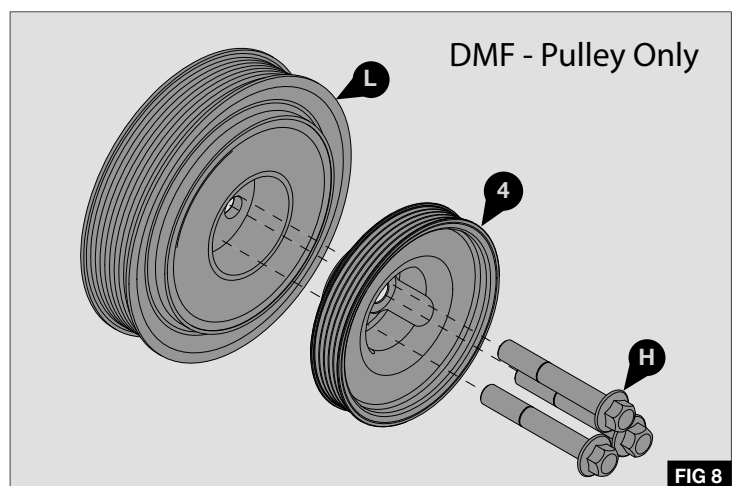

FIG 8

- Lock the starter ring and tighten the bolts (H) in the following sequence. See Fig 9:

First Stage - Torque all three bolts to 45 Nm using a calibrated torque wrench.

Second Stage - Tighten to 120 Degrees using a torque angle gauge.

- Reinstall the viscous fan assembly previously removed and tighten using a viscous fan wrench
- Reinstall the starter motor and cable previously removed.
- Torque the starter motor bolts (E) to 25 Nm using a calibrated torque wrench.

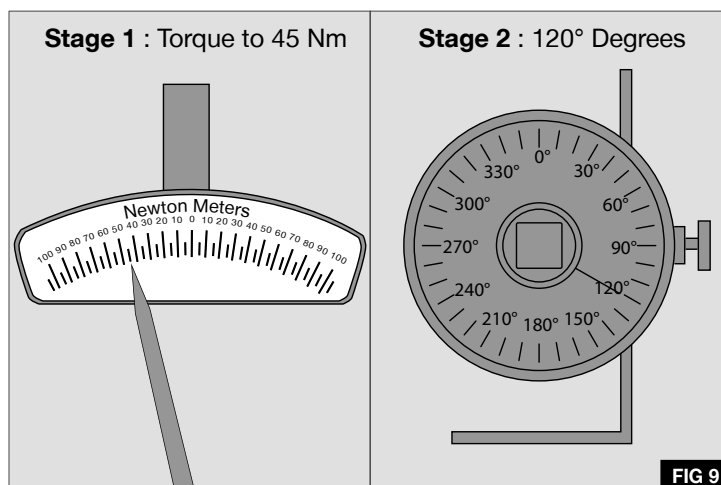

IDLE PULLEY INSTALLATION

- Remove and discard the original idle pulley (M) and original M10 bolt - Fig 10
- Fit the supplied Idle pulley (6) into the same position as the discarded original idle pulley and fix with bolt (8) M10 x 60 - Fig 10

Warning: Align the supplied idle pulley (6) with the two hole in the horizontal position - Fig 10

- Torque bolt (8) M10 x 60 to 50 Nm using a calibrated torque wrench.

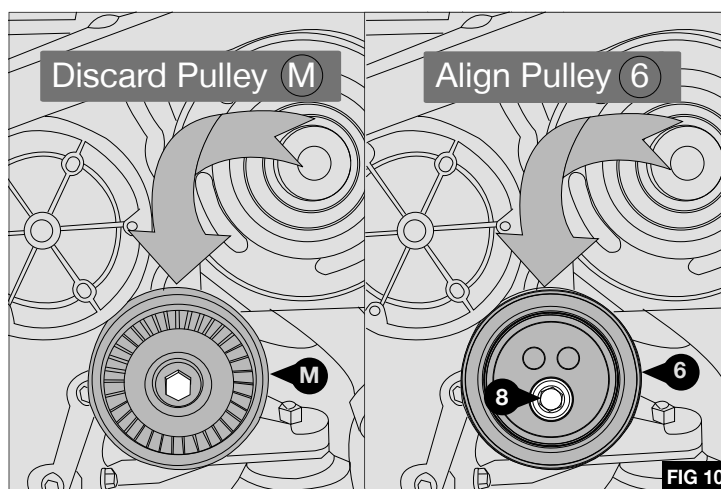

TENSIONER INSTALLATION

- Assemble the idle pulley assembly as detailed in Fig 11, do not fully tighten the nut (21) or M8 x 80 bolt (15) - Fig 11

Warning: Check the two Split Dowel Bushes (2) are fitted in the compressor mount bracket (1)

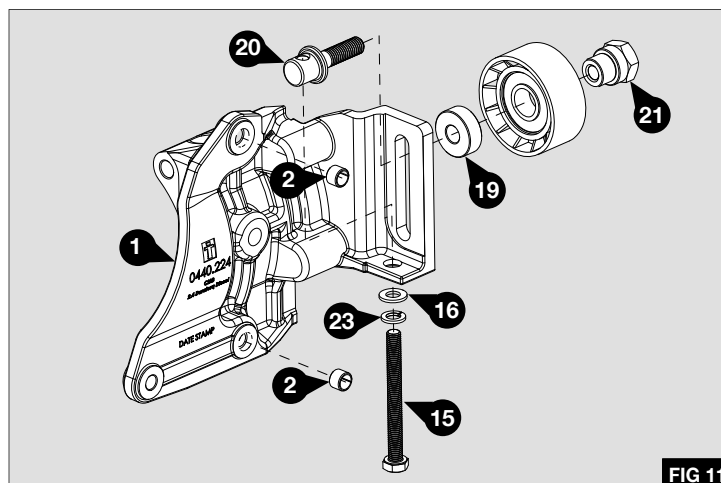

MOUNT BRACKET INSTALLATION

- Install the compressor mount bracket (1) to the engine block using bolts (9) M8 x 35 - Fig 12
- Torque M8 x 35 bolts (9) to 25 Nm using a calibrated torque wrench

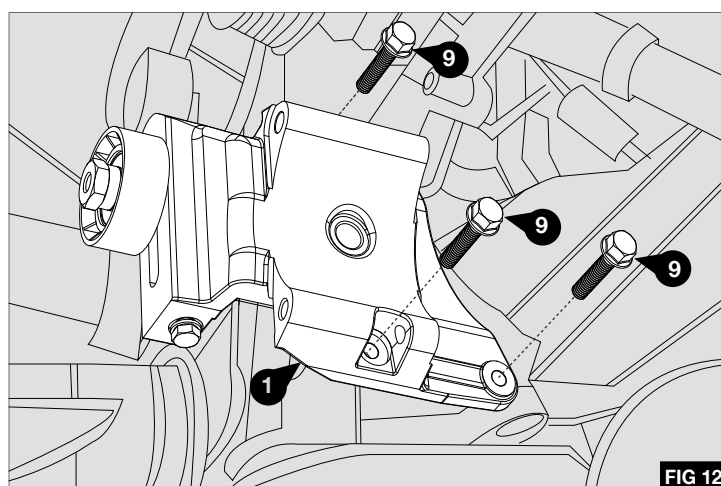

COMPRESSOR INSTALLATION

1. Fit the compressor to the previously fitted mount bracket assembly (1) using bolt (12) M10 x 130 with M10 Schnorr safety washer (13) and M10 flat washer (14) and Durlok M10 nut (11) then secure with M10 x 30 bolts (10) - Fig 13
2. Torque bolts (10) and (12) to 50Nm using a calibrated torque wrench.

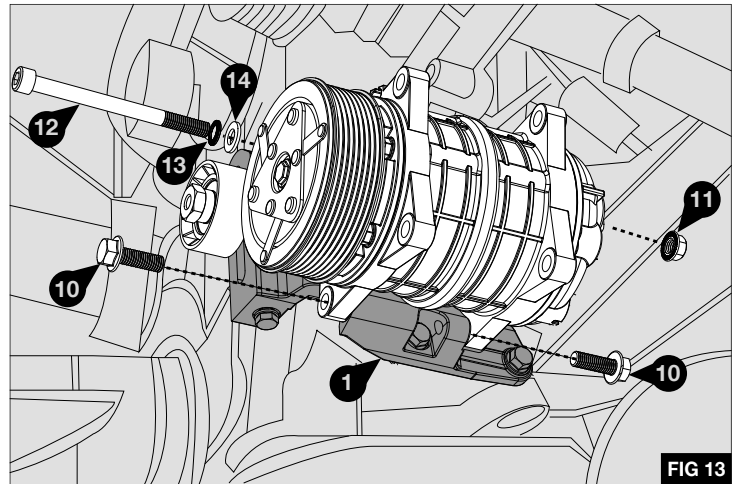

FIG 13

DRIVE BELTS

1. Refit the original manufacturer's drive belt (C) previously removed to the engine in the same configuration and in accordance with the original manufacturer's design detailed in - Fig 14

- CP** Crankshaft pulley damper
AT Automatic belt tensioner
AL Alternator
PS Power steering pump
IP Idle pulley
VF Viscous Fan
WP Water pump

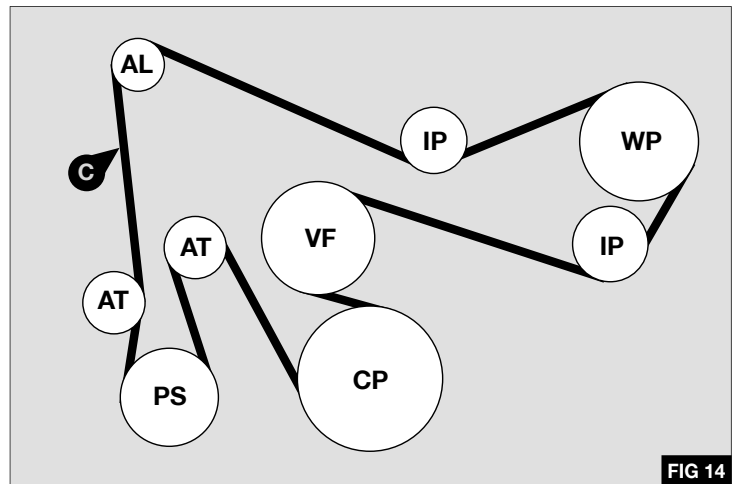

FIG 14

2. Install the supplied compressor drive belt (5) as detailed in Fig 15

NB: Where applicable and dependent on, the compressor model, align the supplied drive belt by installing in the correct clutch groove - Fig.16

Seltec PV8 has the same gauge line (46.55) as the Sanden PV6 & PV7, belt is fitted to front groove.

Sanden PV8 has a unique gauge line (50.11) in most cases, belt is fitted to second groove. If in any doubt, please check with your compressor supplier.

3. Tension the compressor drive belt (see table below) by tightening the draw bolt (15)

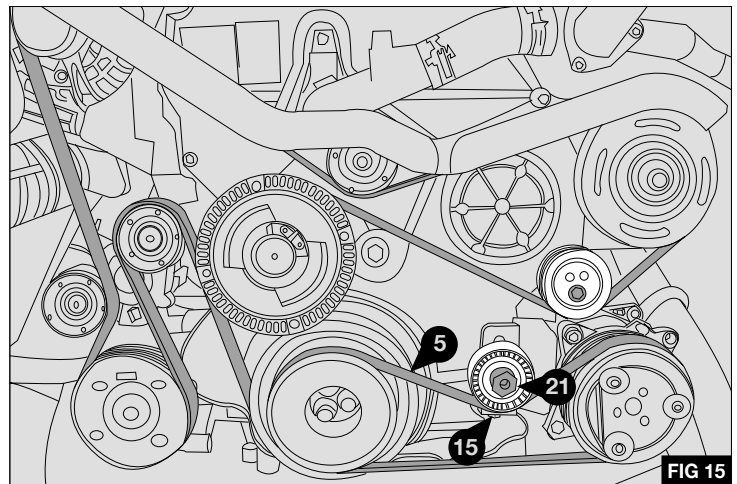

FIG 15

Belt Tension Table

Belt Life	Belt Tension
New Belt	55 - 65 kg
Used Belt	40 - 45 kg

4. Once the correct tension has been attained, lock the idle pulley assembly with nut (21) - Fig 15
5. Torque nut (21) to 35 Nm

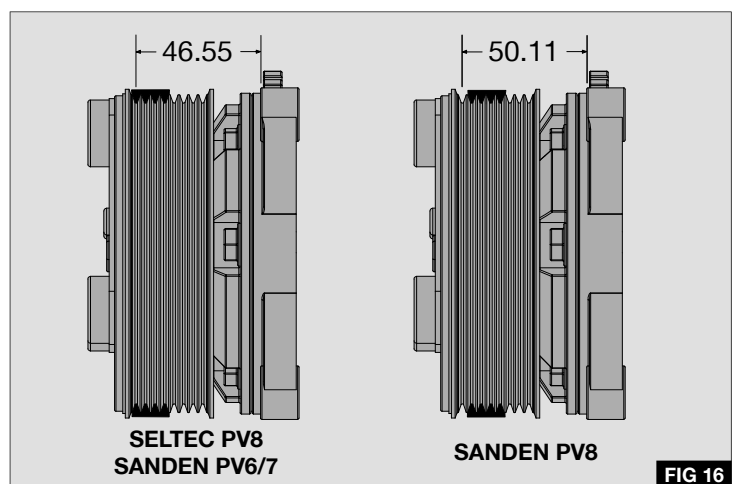

FIG 16

POST INSTALLATION

1. Check the clearance between the radiator hose and the compressor assembly.
2. If necessary, unclip the plastic clip (N) from the radiator hose (O) then move the radiator hose (O) in the direction shown to allow for clearance against the compressor assembly - Fig 17
3. Re attach the clip (N) with the hose in the new position - Fig 17

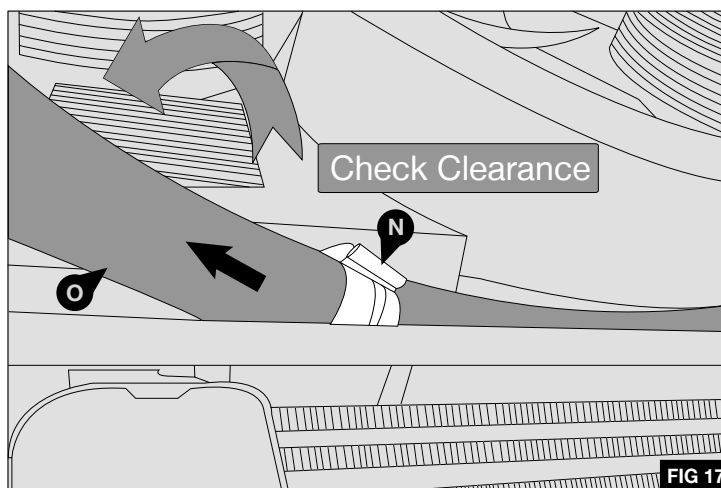

FIG 17

4. Before starting the engine check all the installed parts and ensure that the belt is installed correctly. Run the unit for at least ten minutes, then check the whole mounting assembly and previously removed parts. Attach the supplied warning label on to a suitable location.

Warning: Ensure that there is clearance between the radiator hoses and the compressor assembly of at least 30 mm - Fig 18

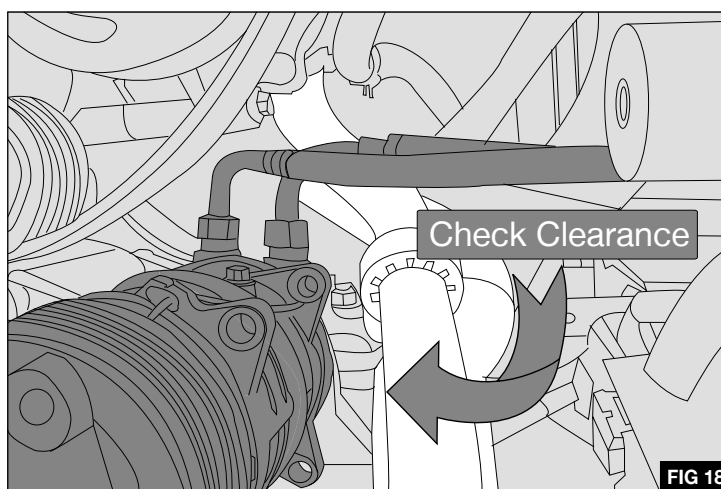

FIG 18

(EN)

Techni focuses on constant upgrading of its products. The Manufacturer reserves the right to modify the models and components described in the present publication at any time for technical or commercial reasons and without prior notice. For further information, contact Techni technical services.

(DE)

Techni ist stets bestrebt die eigenen Produkte zu verbessern. Die Herstellerfirma behält sich das Recht vor, aus technischen oder Verkaufsgründen, zu jeder Zeit und ohne vorherige Ankündigung, Abänderungen an den Modellen und den in dieser Veröffentlichung beschriebenen Einbauteile vorzunehmen. Für weitere Informationen bitten wir Sie, sich an unseren Techni Kundendienst zu wenden.

(FR)

Techni vise à une amélioration constante des ces produits. La maison se réserve le droit d'apporter, à tout moment et sans préavis, des modifications aux modèles et aux composants décrits dans cette publication pour des raisons d'ordre technique ou commerciale. Pour d'ultérieures informations s'adresser au service d'assistance Techni.

(IT)

Techni mira ad un costante miglioramento dei propri prodotti. La Casa si riserva il diritto di apportare in qualunque momento e senza preavviso modifiche ai modelli e ai componenti descritti in questa pubblicazione per ragioni di natura tecnica o commerciale. Per ulteriori informazioni rivolgersi al servizio assistenza Techni.

(ES)

Techni aspira a un constante mejoramiento de su producción. La Fábrica se reserva el derecho de aportar en cualquier momento y sin preaviso modificaciones a los modelos y los componentes descritos en esta publicación por razones técnicas o comerciales. Para ulteriores informaciones dirigirse al servicio asistencia Techni.

VENDITA E SERVIZIO
VENTE ET SERVICE

SALES AND SERVICE
VERKAUF UND SERVICE



Sundorne Trade Park, Henley Way,
Shrewsbury, United Kingdom, SY1 4NS
Telephone (+44) (0) 1743 443176
Fax (+44) (0) 1743 443113
Email: sales@techni.co.uk